

**TUBULAR FULL VIEW SIGHT GLASS,
T-BUSH DESIGN, TUBULAR SIGHT GLASS**

- FLUID / FLOWING MEDIA WILL NOT BE CONTACTED TO FLANGE MATERIALS.
- BEST OPTION FOR STAINLESS STEEL SIGHT GLASS.

SIZE	ØNB	F	Ø OD	FT	ØRf	ØPCD	Ød	N
25	25	175	108	15	51	79.2	16	4
40	38	178	127	16.5	73	98.5	16	4
50	50	180	152.4	17.5	92	120.6	19	4
65	65	183	178	19	105	139.7	19	4
80	75	189	190.5	22	127	152.4	19	4
100	100	193	228.6	24	157	190.5	19	8
150	150	196	279.4	25.5	216	241.3	22.2	8

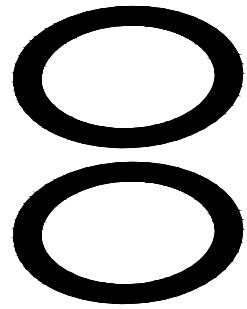

2x PTFE
GASKET

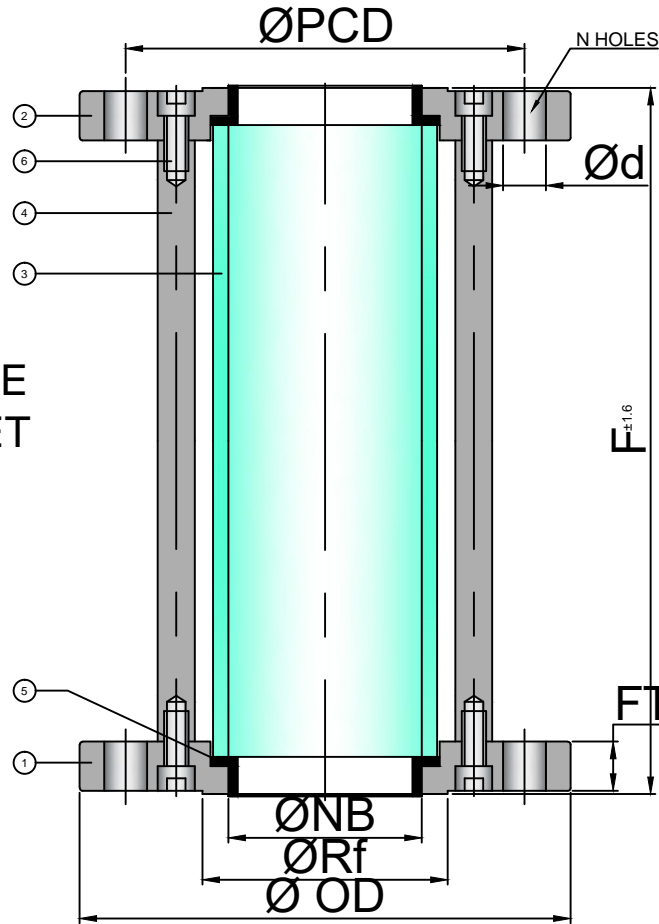

P.NO	NOMENCLATURE	MATERIAL	QTY.
6	LN KEY BOLT	C.S. / SS304 / SS316	4/8/12
5	SEAT	T-BUSH DESIGN PTFE	2
4	TIE BAR	C.S. / SS304 / SS316	4/8/12
3	GLASS TUBE	BOROSILICATE	1
2	TOP FLANGE	C.S. / CF8 / CF8M	1
1	BOTTOM FLANGE	C.S. / CF8 / CF8M	1

BILL OF MATERIAL

----- X -----

-: Special Features :-

1. Wetted Parts PTFE & Glass Tube Only.
2. Full visualize design
3. Easy Maintenance
4. Unrestricted Full Bore Flow

-: Available Options :-

1. Welded Frame
2. Any Special Length (F to F - (A))
3. Outer Finish Powder coated / Zinc Plated / Paint for CS Sight Glass.
4. Outer Finish Mirror Polish / Electro Polishing / Mate Finishing for SS Sight Glass.

CONSTRUCTION:- LN KEY FITTED , T-BUSH DESIGN SOFT SEAT ,
FULL VIEW , BORO SILICATE TUBULAR SIGHT GLASS

DESIGN & MFG. CODE	MFG.
INSPECTION & TESTING	API 598
FACE TO FACE	MFG. (SHOWN IN DRAWING)
END CONNECTION	ASME B 16.5 R/F CONC. SERRATED / BS10 TABLE D/E/F
CLIENT	
P.O. NO.	

	HYDROSTATIC PRESSURE TESTING	PNEUMATIC PRESSURE TESTING
SHELL (BODY)	kg/cm ² Psig BAR 5 71 5	- - -
SEAT	kg/cm ² Psig BAR - - -	- - -

RATING	NOMINAL SIZE	DESCRIPTION		MATERIAL
ASA 150 #	AS SHOWN	ASSEMBLY		AS SHOWN
SCALE	END CONNECTION	STANDARD	ALL DIMENSIONS ARE IN M.M. UNLESS OTHERWISE SPECIFIED	
NTS	FLANGED	MFG.	DESIGN	DATE
PROJECTION	REMOVE SHARP CORNERS			CHECKED
THIRD ANGLE	UNSPECIFIED TOLERANCES FOR MACHINED DIMENSIONS			DATE
	0-75	75-300	300-600	ABOVE 600
	±0.20	±0.40	±0.50	±0.75
SHARVIL ENGINEERS				REV.
147, ADARSH ESTATE, RAKHIAL, AHMEDABAD.-380 023.				00
Apnex				DRG. No.
SE/SG-TUBULAR/FP/1501-6				

FOR REFERENCE

FOR APPROVAL

FOR RECORD